

11500 / 24788**INFINITI EX35 JOURNEY (AWD INCLUDED)**

5/12/08

GROSS LOAD CAPACITY WHEN USED AS A WEIGHT CARRYING HITCH: 2,000 LBS. TRAILER WEIGHT & 200 LBS. TONGUE WEIGHT.*****DO NOT EXCEED VEHICLE MANUFACTURER'S RECOMMENDED TOWING CAPACITY.*****

Parts List			
ITEM	QTY	PART NUMBER	DESCRIPTION
1	2	1_2 FISHWIRE	1/2" FISHWIRE
2	2	HFN 1213	HEX FLANGE NUT
3	4	M8 - 1.25 x 30 TAP BOLT	HEX HEAD TAP BOLT
4	4	3/8"	CONICAL TOOTHED WASHER
5	2	1/2-13 x 1 3/4	CARRIAGE BOLT
6	2	CM-SP4	.250 x 1.50 x 3.00" SQUARE HOLE SPACER

FISHWIRE TECHNIQUE

INSERT COILED END OF FISHWIRE TOOL THROUGH HITCH MOUNTING HOLE IN VEHICLE FRAME RAIL AND OUT THE ACCESS HOLE. PASS COILED END OF FISHWIRE THROUGH SPACER AND THREAD BOLT INTO COIL. KINK WIRE TO KEEP SPACER SEPARATE FROM BOLT AS SHOWN. PULL FISHWIRE, SPACER, AND BOLT THROUGH FRAME AND OUT MOUNTING HOLE. USE FISHWIRE TO GUIDE HITCH DURING MOUNTING AND PREVENT LOSS OF BOLT / SPACER INSIDE FRAME RAIL.

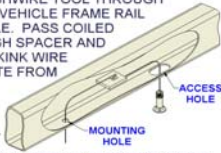

NOTE: SOME VEHICLES MAY FISHWIRE THROUGH END OF FRAME

TOOLS REQUIRED

STRAIGHT SCREW DRIVER
RATCHET
3" SOCKET EXTENSION
10" SOCKET EXTENSION
RATCHET KNUCKLE
10mm SHORT SOCKET
12mm SHORT SOCKET
1/2" SHORT SOCKET
3/4" SHORT SOCKET
TORQUE WRENCH
17/32" DRILL BIT

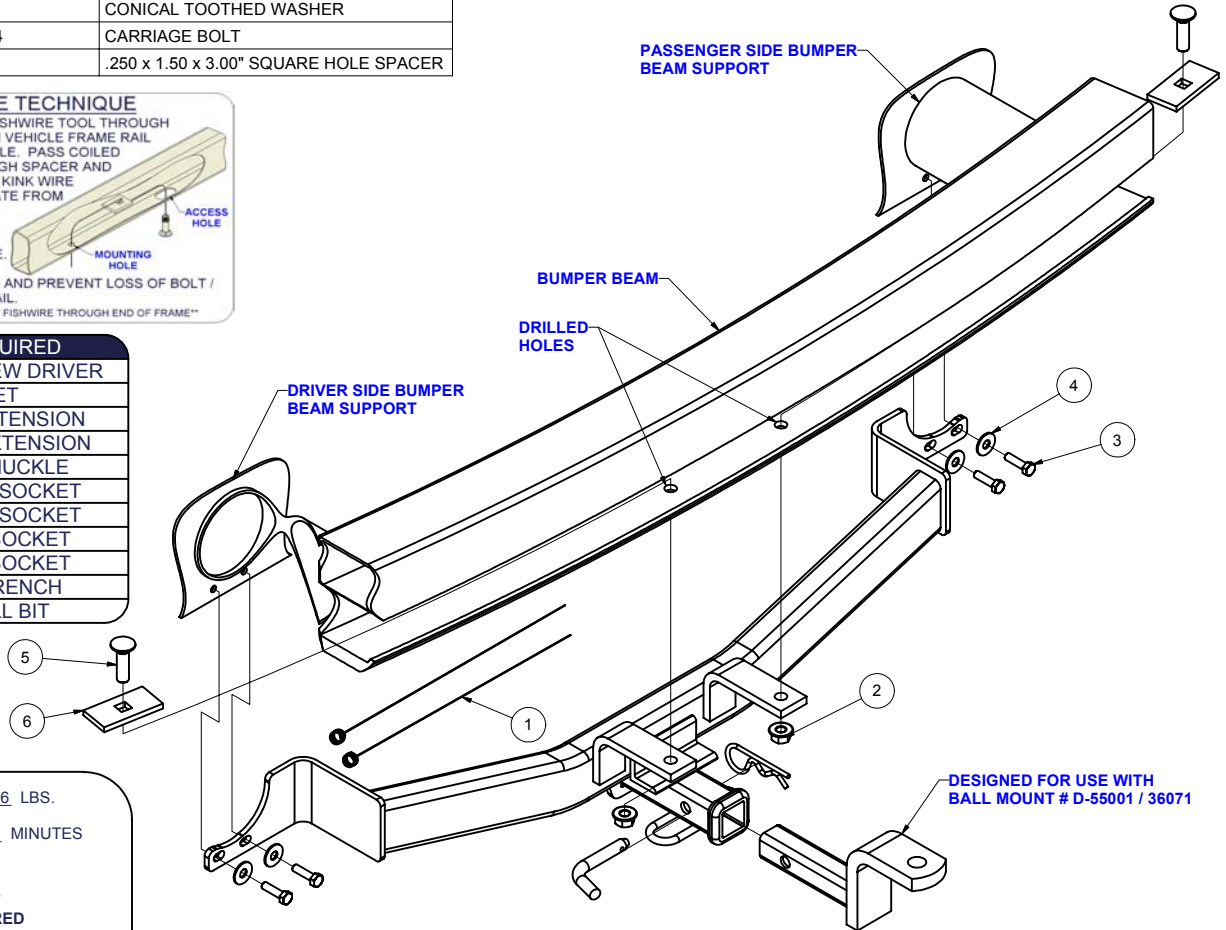
HITCH WEIGHT: 26 LBS.INSTALL TIME: 60 MINUTES

INSTALL NOTES:

- LOWER EXHAUST
- DRILLING REQUIRED
- FISHWIRE HARDWARE

INSTALLATION STEPS

- 1) Remove (3) exhaust hanger bolts per side on rear hangers, remove long bolt from driver side hanger on other side of muffler, and remove (1) nut from each of the exhaust hangers just forward from the rear axle. The exhaust should rest on cross brace under the exhaust.
- 2) Remove (2) lower bolts from each bumper beam support.
- 3) Raise hitch into position and loosely install the supplied 8mm bolts. Using the hitch as a template, mark and drill (2) 17/32" holes in the bumper beam.
- 4) Fishwire the 1/2" bolts and spacers into position through the end of the bumper beam, secure with supplied flange nuts.
- 5) Torque all 8mm fasteners to 17 lb-ft and all 1/2" fasteners to 75 lb-ft.
- 6) Re-install all exhaust hangers removed in step 1.

PERIODICALLY CHECK THIS RECEIVER HITCH TO ENSURE THAT ALL FASTENERS ARE TIGHT AND THAT ALL STRUCTURAL COMPONENTS ARE SOUND.

Curt Manufacturing Inc., warrants this product to be free of defects in material and/or workmanship at the time of retail purchase by the original purchaser. If the product is found to be defective, Curt Manufacturing Inc., may repair or replace the product, at their option, when the product is returned, prepaid, with proof of purchase. Alteration to, misuse of, or improper installation of this product voids the warranty. Curt Manufacturing Inc.'s liability is limited to repair or replacement of products found to be defective, and specifically excludes liability for incidental or consequential loss or damage.