

31084 1984 - 2001 JEEP CHEROKEE, COMANCHE, & WAGONEER

5/12/2009

GROSS LOAD CAPACITY WHEN USED AS A WEIGHT CARRYING HITCH: 3,000 LBS. TRAILER WEIGHT & 300 LBS. TONGUE WEIGHT.
 GROSS LOAD CAPACITY WHEN USED AS A STRAIGHT LINE PULL: 9,000 LBS. MAX. LINE PULL.
***** DO NOT EXCEED VEHICLE MANUFACTURER'S RECOMMENDED TOWING CAPACITY. *****
 HAVING INSTALLATION QUESTIONS? CALL TECHNICAL SUPPORT AT 1-800-798-0813

Parts List			
ITEM	QTY	PART NUMBER	DESCRIPTION
1	2	1_2 FISHWIRE	1/2" FISHWIRE
2	2	HFN 1213	HEX FLANGE NUT
3	4	M10 - 1.5 x 35mm	HEX TAP BOLT
4	4	3/8"	CONICAL TOOTHED WASHER
5	2	1/2 - 13 x 2 1/4	CARRIAGE BOLT
6	2	CM-SP1	.250 x 1.50 x 2.00" SQUARE HOLE SPACER
7	2	CM-SP52	.500 x 1.25 x 2.50" ROUND HOLE SPACER

FISHWIRE TECHNIQUE
 INSERT COILED END OF FISHWIRE TOOL THROUGH HITCH MOUNTING HOLE IN VEHICLE FRAME RAIL AND OUT THE ACCESS HOLE. PASS COILED END OF FISHWIRE THROUGH SPACER AND THREAD BOLT INTO COIL. KINK WIRE TO KEEP SPACER SEPARATE FROM BOLT AS SHOWN. PULL FISHWIRE, SPACER, AND BOLT THROUGH FRAME AND OUT MOUNTING HOLE. USE FISHWIRE TO GUIDE HITCH DURING MOUNTING AND PREVENT LOSS OF BOLT / SPACER INSIDE FRAME RAIL.
 NOTE: SOME VEHICLES MAY FISHWIRE THROUGH END OF FRAME

WELDNUT CLEANING
 To remove debris from weldnuts in frame, spray lubricant or compressed air into hole. For heavy debris, use a small wire brush. (Be careful not to damage threads).

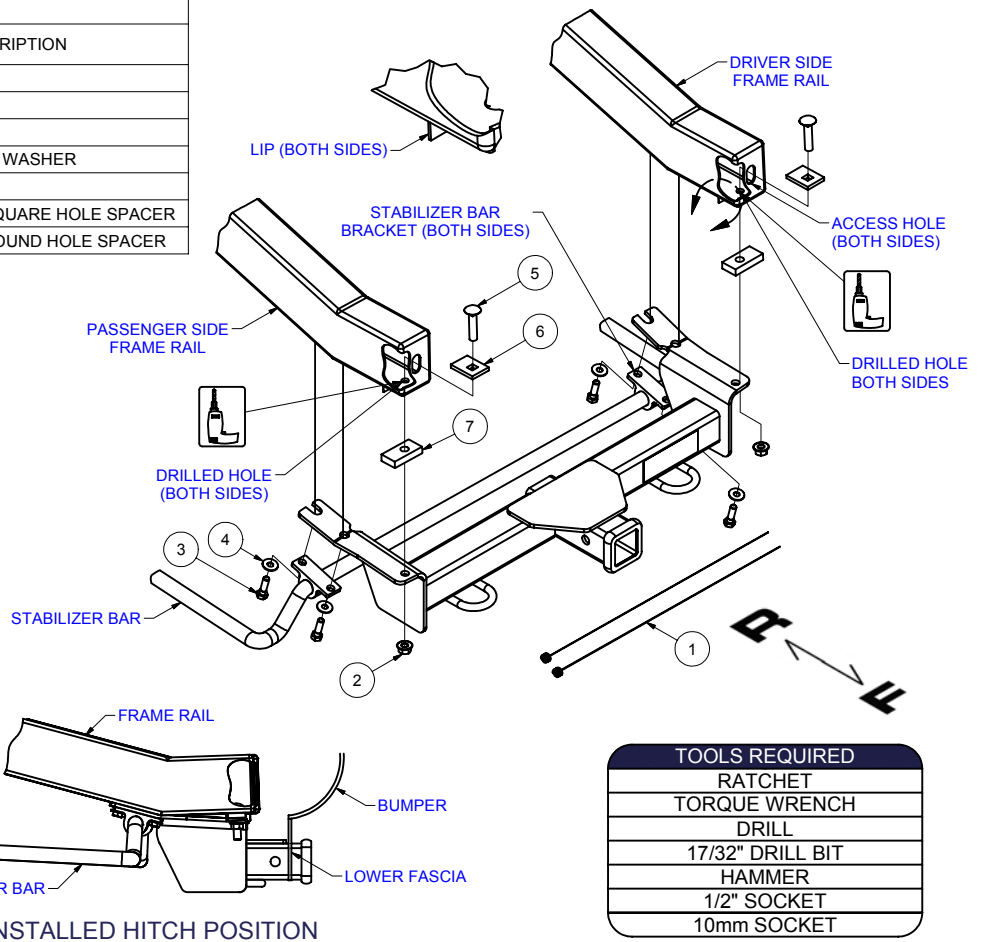

TOOLS REQUIRED
RATCHET
TORQUE WRENCH
DRILL
17/32" DRILL BIT
HAMMER
1/2" SOCKET
10mm SOCKET

HITCH WEIGHT: 29 LBS.
 INSTALL TIME: 30 MINUTES
 INSTALL NOTES:
 -SKID SHIELD REMOVAL
 -FASCIA TRIMMING
 -DRILLING REQUIRED

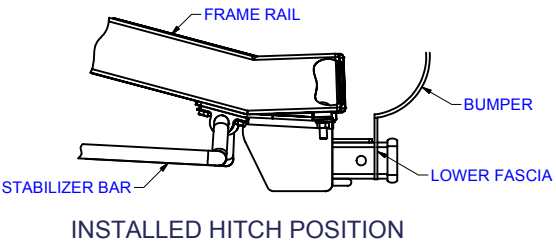

INSTALLATION STEPS

1. If present, remove skid shield and return to vehicle owner.
2. Remove or trim lower fascia to clear hitch. CONSULT VEHICLE OWNER.
3. Remove stabilizer bar fasteners and brackets allowing stabilizer bar to swing free. Return fasteners to owner.
4. Raise hitch, stabilizer bar, and stabilizer bar brackets into position. **NOTE:** The lip on the underside of the frame rails may need to be flattened so SP52 spacers can be installed in step (7).
5. Install 10mm hex bolts and 3/8" conical toothed washers through the stabilizer bar brackets, hitch side plates, and into existing weldnuts as shown.
6. Using hitch as a template drill 17/32" holes into driver and passenger side frame rails as shown.
7. Position SP52 spacers between the frame rails and side plates as shown.
8. Fishwire 1/2" carriage bolts and SP1 spacers through the access holes in frame and out the holes drilled in step (6).
9. Remove fishwires and secure with 1/2" flange nuts.
10. Torque all 1/2" hardware to 75 ft-lbs and 10mm hardware to 35 ft-lbs.

PERIODICALLY CHECK THIS RECEIVER HITCH TO ENSURE THAT ALL FASTENERS ARE TIGHT AND THAT ALL STRUCTURAL COMPONENTS ARE SOUND.

Curt Manufacturing Inc., warrants this product to be free of defects in material and/or workmanship at the time of retail purchase by the original purchaser. If the product is found to be defective, Curt Manufacturing Inc., may repair or replace the product, at their option, when the product is returned, prepaid, with proof of purchase. Alteration to, misuse of, or improper installation of this product voids the warranty. Curt Manufacturing Inc.'s liability is limited to repair or replacement of products found to be defective, and specifically excludes liability for incidental or consequential loss or damage.

31084 1984 - 2001 JEEP CHEROKEE, COMANCHE, & WAGONEER

***DO NOT EXCEED VEHICLE MANUFACTURER'S RECOMMENDED TOWING CAPACITY ***.

FRONT MOUNTED ACCESSORIES

1) Do not exceed front axle Gross Weight Rating (GAWR). Consult owners manual or specification plate located on driver's door frame. Measure gross front axle weight by placing front wheels of loaded vehicle on a scale.

WARNING: Exceeding GAWR may overload the front axle and/or suspension. This could result in **accident, property damage and personal injury.**

- 2) Reposition front mounted license plate if obstructed.
- 3) Do not obstruct vehicle lights.
- 4) Allow free air flow into grille opening.
- 5) Rear wheel traction may be reduced. This could effect handling. Reduce speed and drive with caution.
- 6) Accessories extend front of vehicle. This may reduce approach angle. Use caution when parking and maneuvering.
- 7) Do not obstruct driver view.

VEHICLE RECOVERY AND WINCHING TIPS

1) Use OEM tow hooks, recovery eyes or a clevis mount for attachment of a tow strap or winch cable.

WARNING: NEVER use a ball and/or ball mount as an anchor point for tow strap or winch cable. Severe personal injury or death could result.

- 2) Observe winch manufacturer's recommendations, cautions and warnings.
- 3) Attach return cable to tow hook or recovery eye when using a snatch block (See figure 1).

CAUTION: Do not attach return cable to winch mount. This may overload winch mount and/or front mounted receiver.

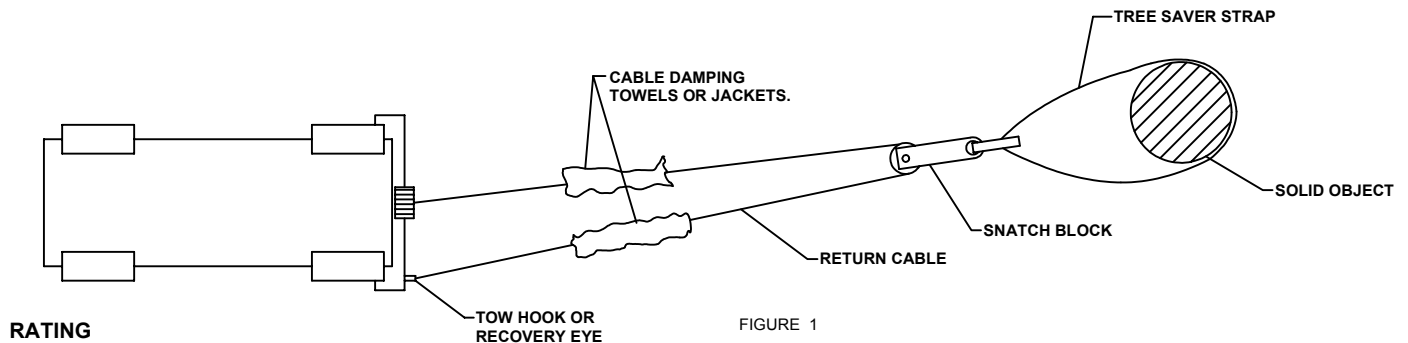

RATING

For **Maximum** line pull rating, winch cable must not exceed:
- 15 degree angle up or down from horizontal (See Figure 2).
- 45 degree angle left or right from straight ahead (See Figure 3).

CAUTION: Exceeding the maximum line pull rating may over load winch, winch mount, and/or front mounted receiver.

