

## 31114 FORD F-250, 350, 450, 550, EXCURSION

ONLY FITS F-450 AND F-550 WITH 34" FRAME

GROSS LOAD CAPACITY WHEN USED AS A WEIGHT CARRYING HITCH: 5,000 LBS. TRAILER WEIGHT & 500 LBS. TONGUE WEIGHT.  
MAXIMUM LINE PULL SHOULD NOT EXCEED 9,000 LBS

**\*\*\*DO NOT EXCEED VEHICLE MANUFACTURER'S RECOMMENDED TOWING CAPACITY.\*\*\***

Parts List			
ITEM	QTY	PART NUMBER	DESCRIPTION
1	4	1/2-13	HANDLE NUT
2	4	CM-SP16	.250 x 1.50 x 2.00" ROUND HOLE SPACER
3	4	1/2"	CONICAL TOOTHED WASHER
4	4	1/2-13 x 1 3/4	HEX BOLT

**NOTE:**

ALL HOLES EXISTING UNLESS OTHERWISE NOTED.

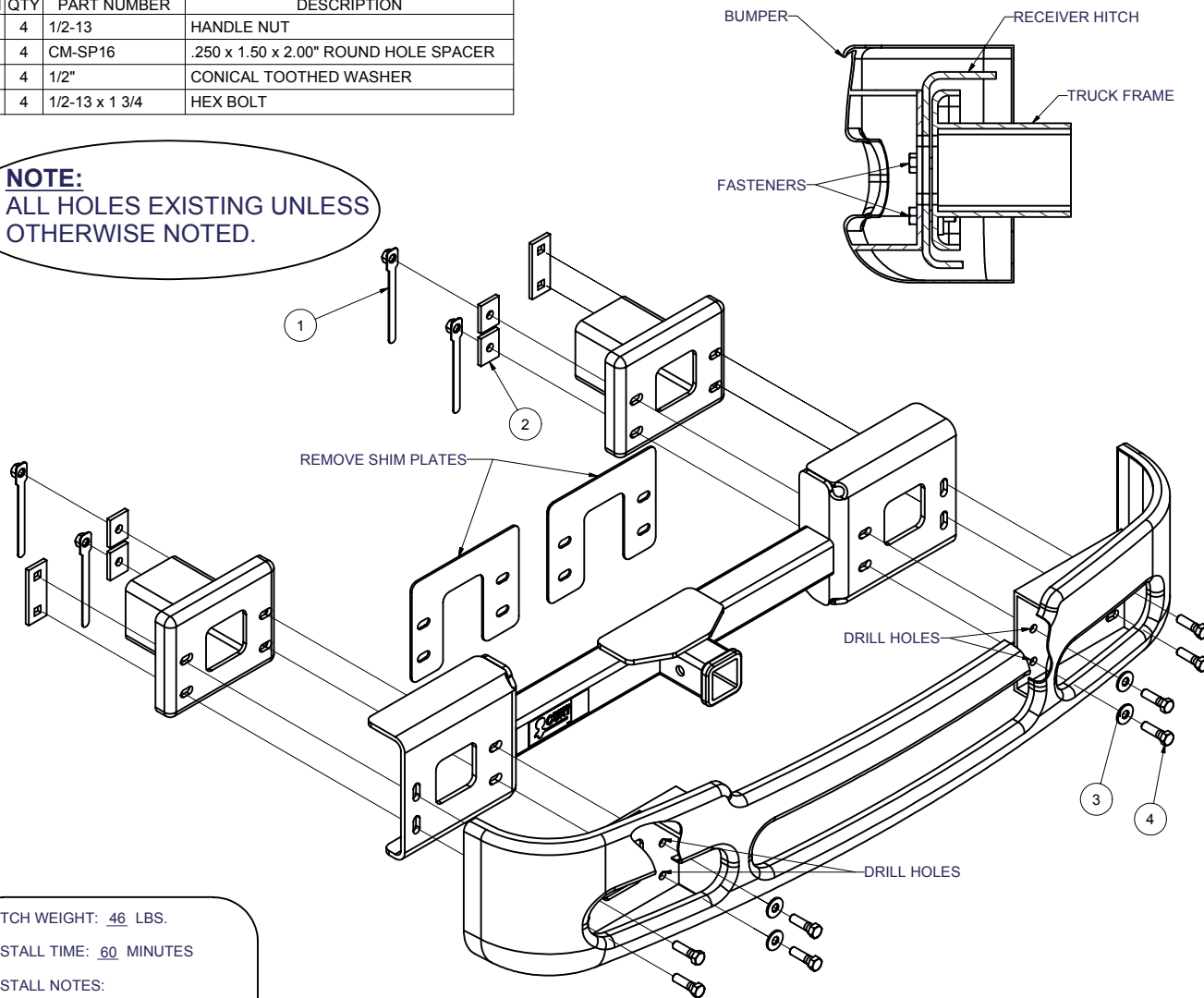

HITCH WEIGHT: 46 LBS.

INSTALL TIME: 60 MINUTES

INSTALL NOTES:

- DRILLING REQUIRED
- REMOVE BUMPER
- REMOVE TOW HOOKS
- REMOVE SHIM PLATES

**\*\*Optional OEM fog lights must be removed for hitch installation\*\***

### INSTALLATION STEPS

1. Remove bumper, shim plates and tow hooks if present.
2. Place receiver hitch inside bumper and line up outside holes.
3. Using the hitch as a template mark the required drill holes. Drill holes with 5/8" drill bit.
4. Place hitch over the ends of frame rails. Mount the bumper onto the hitch using existing and supplied hardware.
5. Torque all 1/2" fasteners to 75 lb-ft.

**PERIODICALLY CHECK THIS RECEIVER HITCH TO ENSURE THAT ALL FASTENERS ARE TIGHT AND THAT ALL STRUCTURAL COMPONENTS ARE SOUND.**