



# J&D Manufacturing



LEADERS IN COW COMFORT

## Steel MAG Bi-Fold Foldaway Hinge

Our new Bi-Fold Foldaway Hinge turns any two J&D Steel Make-A-Gates into a custom Bi-Fold Foldaway Gate. The bolt on design allows for quick and easy installation without drilling or welding. Depending on the mounting location, the HG48 hinge creates either a bi-fold gate with a 260° range of motion, or a bi-fold gate that folds away flat. Great alternative to telescoping gates.

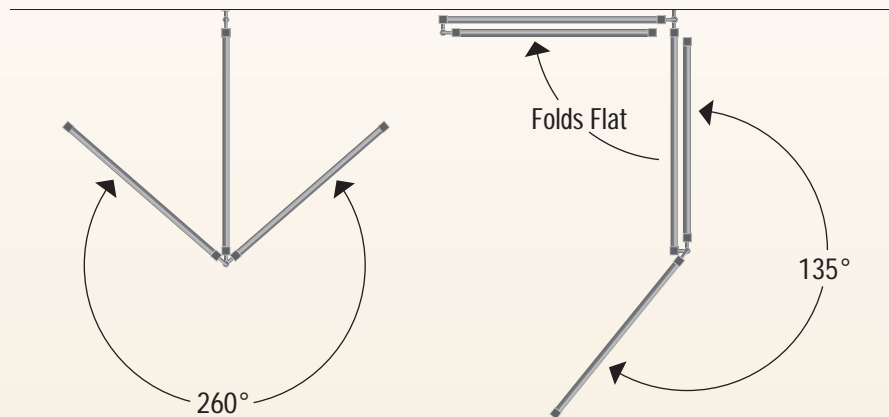

Mount hinge on the end of the gate to create a bi-fold with a 260° swing.

Mount hinge on the left or right side of the gate to create a bi-fold that will swing flat and fold completely away.

### Features:

- Turn our Steel Make-A-Gate into a bi-fold or a bi-fold foldaway
- Can be used to direct livestock traffic with multiple lane positions
- Hot dip galvanized hinges
- Quick and easy bolt on design
- Sold in pairs with mounting hardware

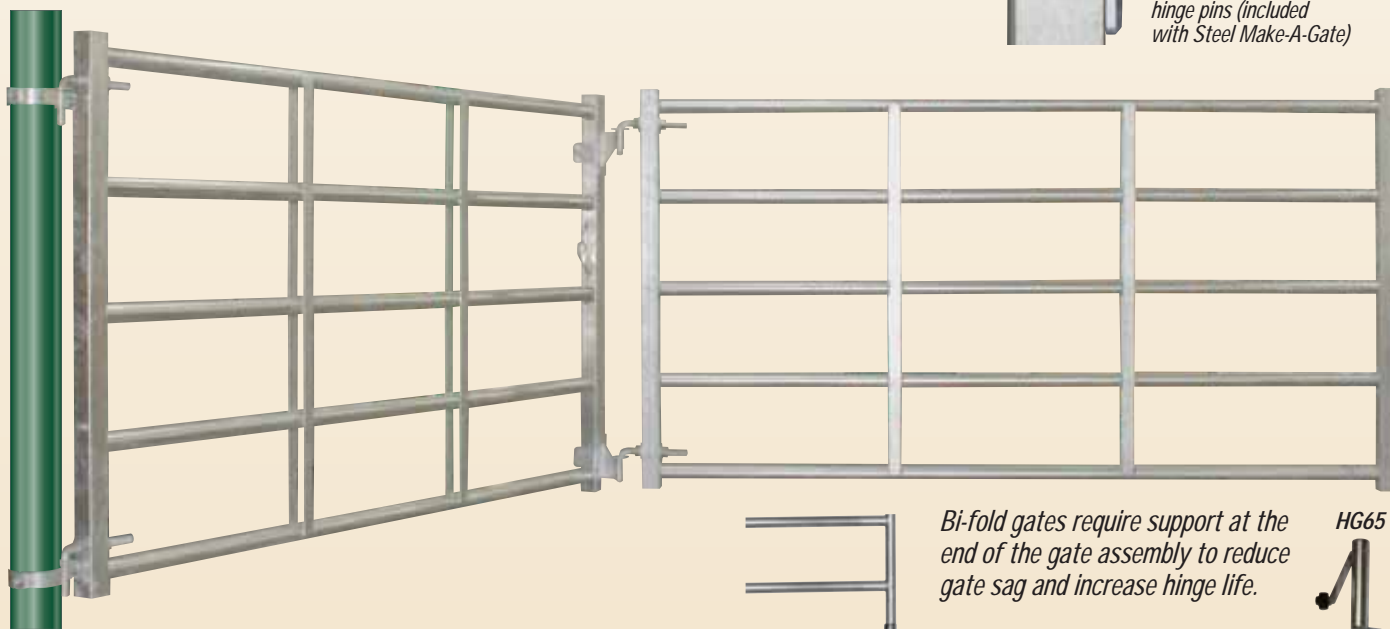

*Bi-fold gates require support at the end of the gate assembly to reduce gate sag and increase hinge life.*

*J&D highly recommends using our HG65 adjustable height gate wheel when creating a bi-fold gate. The 360° swivel will follow the swing of the gate when opening or closing.*



Part#	Description
HG48	(2) Bolt on Hinges for Steel Make-A-Gate, with Hardware
Accessories	
HG65	Gate Wheel, Adjustable Height



LEADERS IN COW COMFORT

# Round Tube Bolt On Gate Hinges

## J&D Manufacturing is your Gate Accessory Headquarters!

Our new round tube gate hinges provide a flexible option when hanging your gates. The bolt on design allows you to adjust the gate height at any time without drilling new holes or creating a new weld.



### Features:

- Hot dip galvanized for long life
- Quick and easy bolt on design
- Hinges to mount 1 5/8", 1.9" tubes to 1 5/8", 1.9", 4" posts
- Sold in pairs with mounting hardware



HGF340



HGF341



HGF342



HGF343



HGF344

Part#	Description
HGF340	(2) Bolt On Hinges, 1.9" Tube to 4" Post, with Hardware
HGF341	(2) Bolt On Hinges, 1.9" Tube to 1 5/8" Post, with Hardware
HGF342	(2) Bolt On Hinges, 1.9" Tube to 1.9" Post, with Hardware
HGF343	(2) Bolt On Hinges, 1 5/8" Tube to 4" Post, with Hardware
HGF344	(2) Bolt On Hinges, 1 5/8" Tube to 1 5/8" Post, with Hardware



# J&D Manufacturing



LEADERS IN COW COMFORT

## Round Tube Bi-Fold Foldaway Gate Hinges

Our new Bi-Fold Hinges turn your round tube gates into a custom Bi-Fold Foldaway Gate. The bolt on design allows you to adjust the gate height at any time without drilling new holes or creating a new weld. Bi-Fold gates give you greater control when directing livestock traffic flow.

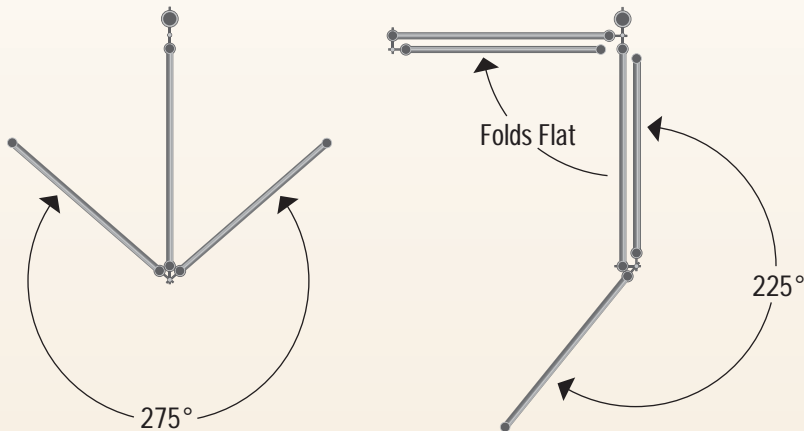

Mount hinge on the end of the gate to create a bi-fold with a 275° swing.

Mount hinge on the left or right side of the gate to create a bi-fold that will swing flat and fold completely away.

### Features:

- Turn your round tube gate into a custom bi-fold or bi-fold foldaway gate!
- Hot dip galvanized hinges
- Quick and easy bolt on design
- Fits gates with 1½" or 1.9" round tubes
- Sold in pairs with mounting hardware

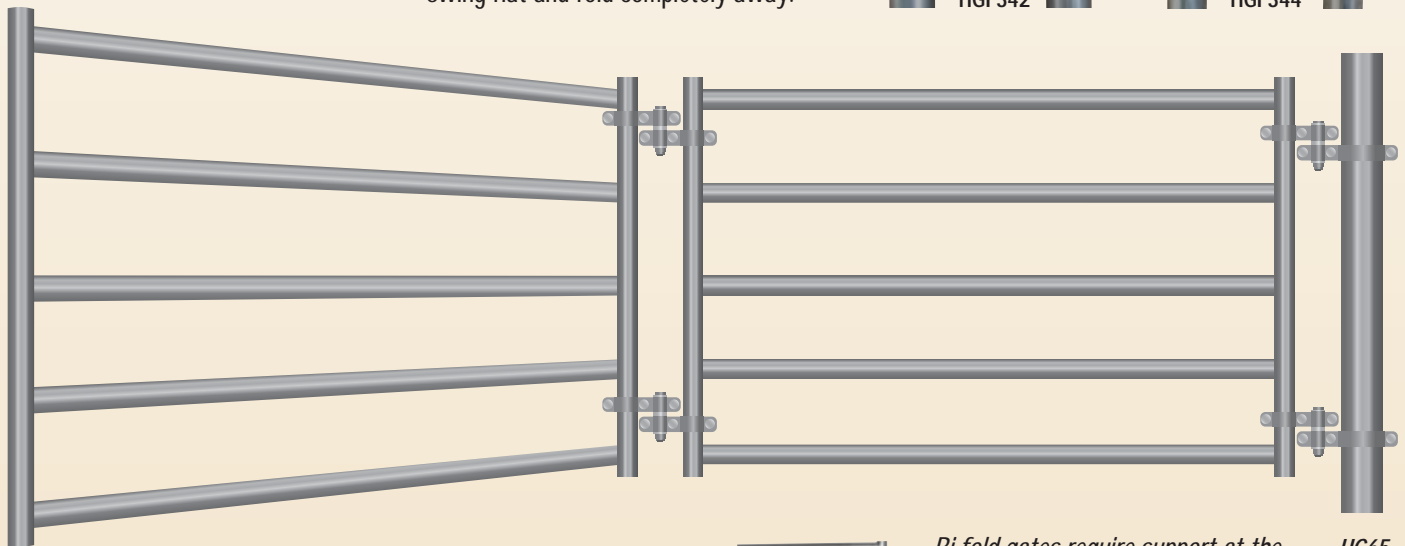

Part#	Description
HGF342	(2) Bolt On Hinges, 1.9" Tube to 1.9" Tube, with Hardware
HGF344	(2) Bolt On Hinges, 1½" Tube to 1½" Tube, with Hardware
Accessories	
HG65	Gate Wheel, Adjustable Height



*Bi-fold gates require support at the end of the gate assembly to reduce gate sag and increase hinge life.*

*J&D highly recommends using our HG65 adjustable height gate wheel when creating a bi-fold gate. The 360° swivel will follow the swing of the gate when opening or closing.*





# J&D Manufacturing



LEADERS IN COW COMFORT

## Gate Latches & Mounting Brackets

### J&D Manufacturing is your Gate Accessory Headquarters!

J&D has three different latch options to meet your needs and budget. The HP40W is the top-of-the-line, rugged spring loaded latch. Our HP70 is our mid-priced, two-way lockable self catching latch and peg. Both latches are designed to be bolted directly to a wall or wood post, or can also be bolted or welded on a round or flat surface using our new mounting brackets. For the more economical gate latch option, choose the J&D chain latch assembly.

#### HP40W Heavy Duty Spring Loaded Self Catching Latch

- Two-way spring loaded latch
- Bolt onto a wall or wood post (bolts not included)
- Weld or bolt onto a steel post using our optional mounting brackets
- Bolt on pegs available for 2" or 2 1/4" square tube (sold separately)
- Hot dip galvanized finish



HP40W

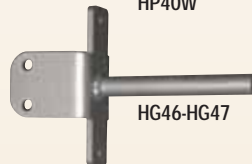

HG46-HG47

#### HP70 Self Catching Latch and Peg

- Two-way self catching latch
- Bolt onto a wall or wood post (bolts not included)
- Weld or bolt onto a steel post using our optional mounting brackets
- Includes bolt on peg for 1 5/8" or 1.9" round tube, or 2" square tube
- Lockable using standard padlock (not included)
- Black powder coat finish



HP70



#### Mounting Brackets

- Brackets compatible with HP40W and HP70 gate latches
- HGF320 & HGF325 brackets can be bolted to 1 5/8" or 4" tubes and are hot dip galvanized for long life
- HGF350 weld on bracket fits 2 7/8" post, 4" post, or a flat surface and has painted finish for easy welding

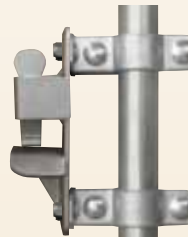

HGF320



HGF325



HGF350



HGF320

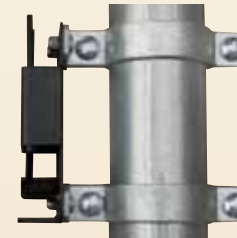

HGF325



HGF350

Part#	Description
<b>Gate Latches</b>	
HP40W	Wall Latch, Self Catching, Hot Dip Galvanized
HG46	Peg, Bolt On for Supreme Gate 2"
HG47	Peg, Bolt On for MAGS, 2 1/4"
HP70	Wall Latch and Peg, Black, Packaged
<b>Gate Latch Mounting Options</b>	
HGF320	(2) Gate Latch Mount, Bolt On, 1.66" Post, with Hardware
HGF325	(2) Gate Latch Mount, Bolt On, 4" Post, with Hardware
HGF350	Latch Bracket, Weld On, 2 7/8" or 4" Post, with Hardware
<b>Additional Options</b>	
HK133	Chain Latch Assembly

#### HK133 Chain Latch Assembly

- Heavy duty 36" chain
- Includes push in snap, quick link and lap link

HK133





# J&D Manufacturing



LEADERS IN COW COMFORT

## Gate Hinge Pins & Pocket Mounts

### J&D Manufacturing is your Gate Accessory Headquarters!

Our custom mounting options give you the flexibility you need when installing your steel or fiberglass gates. All hinge pocket mounts are designed to fit our standard HGF150 hinge pins. The HGF150 hinge pins have a heavy 7/8 thread and can be fully adjusted AFTER installing your gates.

#### Features:

- Hot dip galvanized for long life
- No restrictions for weight or length of gate
- Quick and easy installation
- Bolt on or weld on mounts
- Flat or round surface mounts
- Hinge pockets for 1 5/8", 1.9" and 4" post
- Sold in pairs

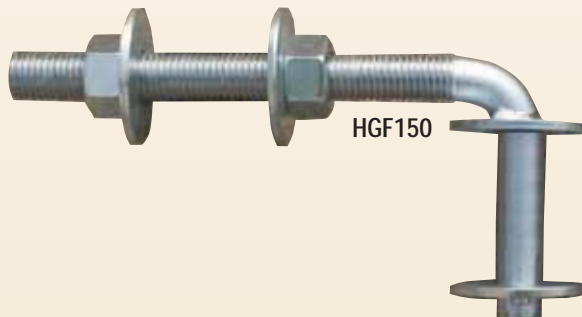

HGF150

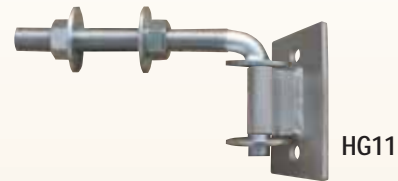

HG11

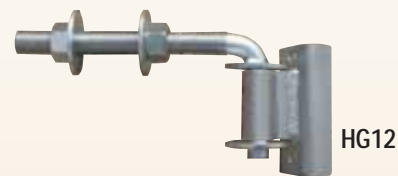

HG12

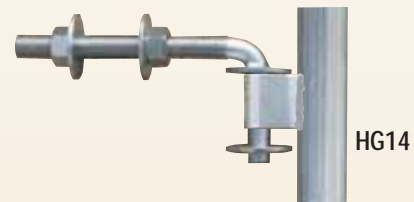

HG14

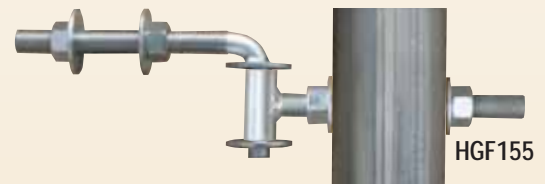

HGF155

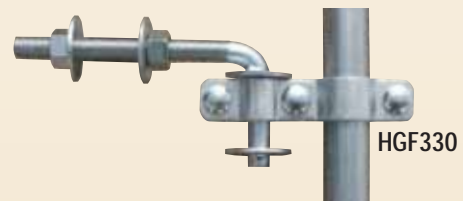

HGF330

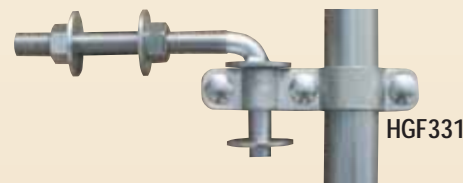

HGF331

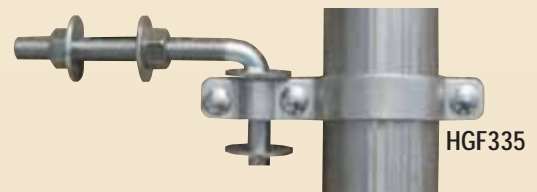

HGF335

Part#	Description
<b>Hinge Pins</b>	
HGF150	(2) Hinge, Gate Thru Bolts Male End, with Hardware
<b>Hinge Pins Pocket Mounting Options</b>	
<b>Bolt On</b>	
HG11	(2) Hinge Pocket, Bolt On, Mount to Flat Surface
HGF155	(2) Hinge Pocket, Thru Bolt, Mount to Wall or Post, with Hardware
HGF330	(2) Hinge Pocket Mount, Bolt On, Mount to 1 5/8" Post, with Hardware
HGF331	(2) Hinge Pocket Mount, Bolt On, Mount to 1.9" Post, with Hardware
HGF335	(2) Hinge Pocket Mount, Bolt On, Mount to 4" Post, with Hardware
<b>Weld On</b>	
HG14	(2) Hinge Pocket, Weld On, Mount to Flat or Round Surfaces
<b>Universal Mount</b>	
HG12	(2) Hinge Pocket, Bolt or Weld On, Mount to Flat or Round Surfaces

\*All parts are pictured using the HGF150 hinge pin for display purposes only. The HGF150 is not included with the hinge pocket mounts.



# J&D Manufacturing



LEADERS IN COW COMFORT

## Gate Wheels

### HG65 Adjustable Height Gate Wheel

The ultimate gate wheel has arrived! Simply bolt the HG65 onto your gate and turn the handle to the proper height. No wrenches...no tools...just quick and easy adjustment. The smooth rolling wheel has a 360° swivel for full range of motion. It's the perfect solution for your bi-fold or foldaway gates. The full swivel will follow the swing pattern and prevent gate sag to extend the life of your gates and latches. No gate too long for this workhorse!

- Quick and easy adjustable crank – no tools needed
- Fits round tubes and square tubes up to 2"
- Compatible with 2" thick fiberglass gates
- Extra heavy duty – up to 1,000 lbs capacity
- Reduces stress on hinges and posts
- Eliminates gate sag
- Tough rust resistant galvanized steel
- Smooth rolling 6" heavy duty plastic wheel

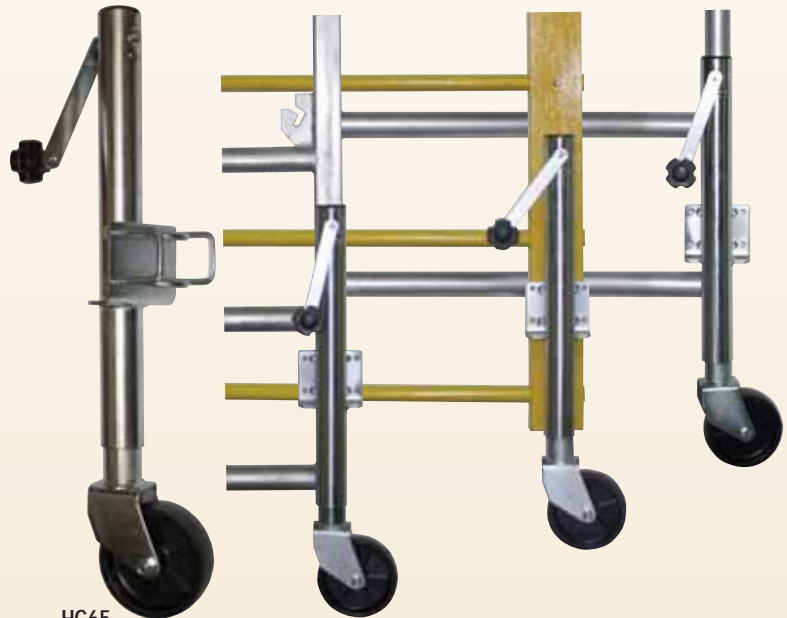

HG65

Part#	Description
HG65	Gate Wheel, Adjustable Height

Dimensions	
Height adjustment	14"
Overall size in extended position	44.5"
Overall size in closed position	30.5"
Overall size from center of mounting bracket to wheel bottom in extended position	32"
Overall size from center of mounting bracket to wheel bottom in closed position	18"

### HG60 Gate Wheel

Our HG60 gate wheel is made from tough rust resistant galvanized steel. It can be bolted directly to a variety of gates including 1 5/8", 1.9" and 2" round or square tube, or even our 2" thick Fiberglass Make-A-Gates.

- Must be mounted to height needed
- Reduces stress on hinges and posts
- Eliminates gate sag
- Tough rust resistant galvanized steel
- Smooth rolling 6" heavy duty plastic wheel
- Fits 1.9" and 2" round or square tube gates
- Compatible with 2" thick fiberglass gates

Part#	Description
HG60	Gate Wheel

Dimensions	
Overall bracket height	8"
Overall bracket and wheel height	10"

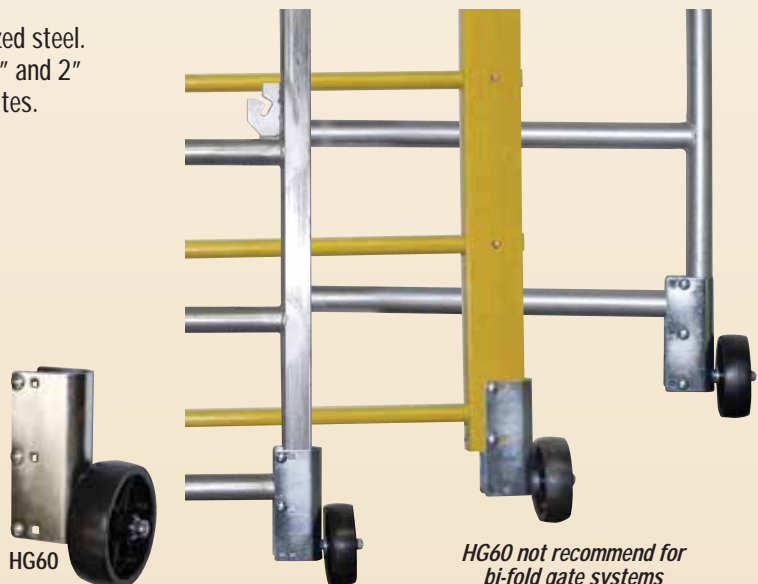

HG60

HG60 not recommend for bi-fold gate systems