



J&D Manufacturing



LEADERS IN COW COMFORT

Round Tube Bi-Fold Foldaway Gate Hinges

Our new Bi-Fold Hinges turn your round tube gates into a custom Bi-Fold Foldaway Gate. The bolt on design allows you to adjust the gate height at any time without drilling new holes or creating a new weld. Bi-Fold gates give you greater control when directing livestock traffic flow.

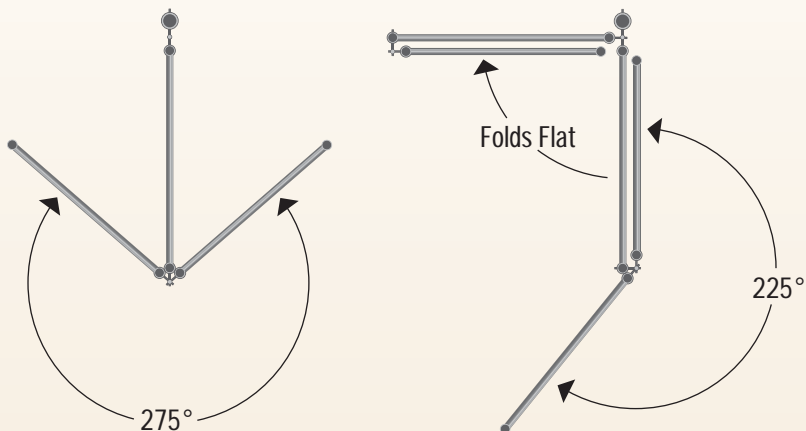

Mount hinge on the end of the gate to create a bi-fold with a 275° swing.

Mount hinge on the left or right side of the gate to create a bi-fold that will swing flat and fold completely away.

Features:

- Turn your round tube gate into a custom bi-fold or bi-fold foldaway gate!
- Hot dip galvanized hinges
- Quick and easy bolt on design
- Fits gates with 1 5/8" or 1.9" round tubes
- Sold in pairs with mounting hardware

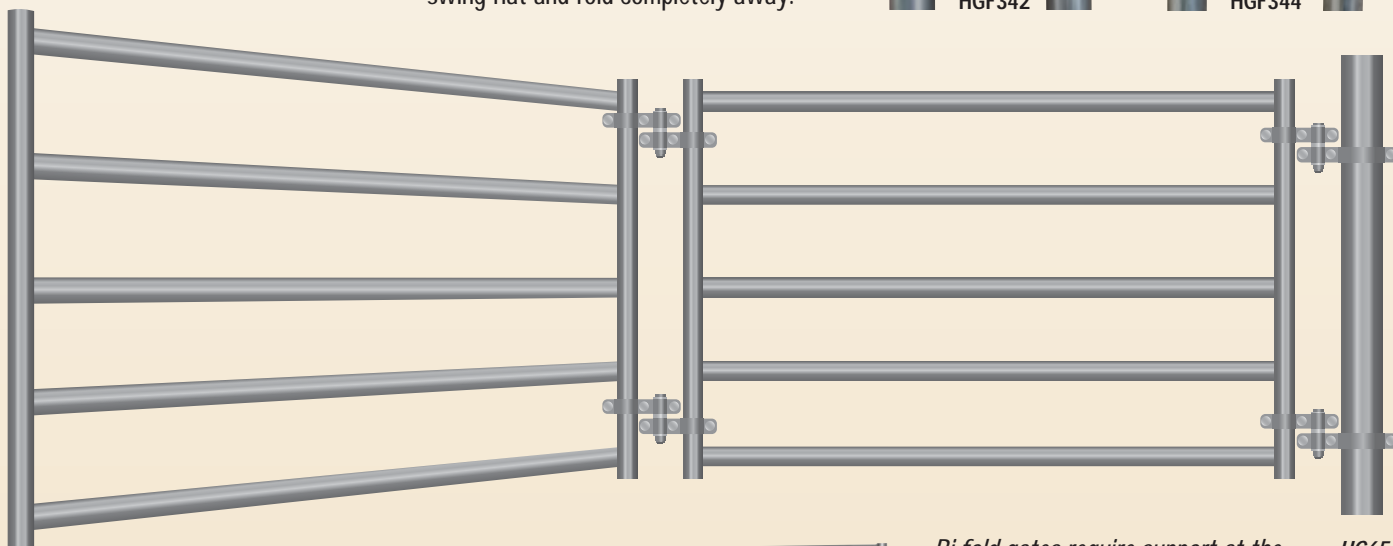

Part#	Description
HGF342	(2) Bolt On Hinges, 1.9" Tube to 1.9" Tube, with Hardware
HGF344	(2) Bolt On Hinges, 1 5/8" Tube to 1 5/8" Tube, with Hardware
Accessories	
HG65	Gate Wheel, Adjustable Height



Bi-fold gates require support at the end of the gate assembly to reduce gate sag and increase hinge life.

J&D highly recommends using our HG65 adjustable height gate wheel when creating a bi-fold gate. The 360° swivel will follow the swing of the gate when opening or closing.

