



# J&D Manufacturing



LEADERS IN COW COMFORT

## Steel MAG Bi-Fold Foldaway Hinge

Our new Bi-Fold Foldaway Hinge turns any two J&D Steel Make-A-Gates into a custom Bi-Fold Foldaway Gate. The bolt on design allows for quick and easy installation without drilling or welding. Depending on the mounting location, the HG48 hinge creates either a bi-fold gate with a 260° range of motion, or a bi-fold gate that folds away flat. Great alternative to telescoping gates.

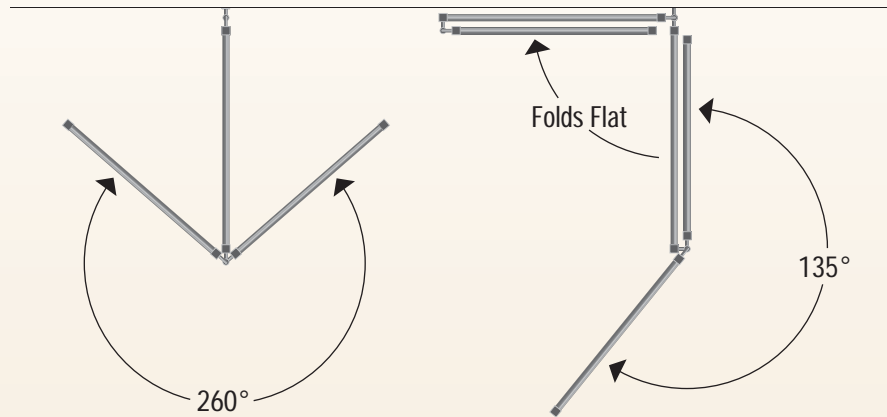

### Features:

- Turn our Steel Make-A-Gate into a bi-fold or a bi-fold foldaway
- Can be used to direct livestock traffic with multiple lane positions
- Hot dip galvanized hinges
- Quick and easy bolt on design
- Sold in pairs with mounting hardware



Mount hinge on the end of the gate to create a bi-fold with a 260° swing.

Mount hinge on the left or right side of the gate to create a bi-fold that will swing flat and fold completely away.

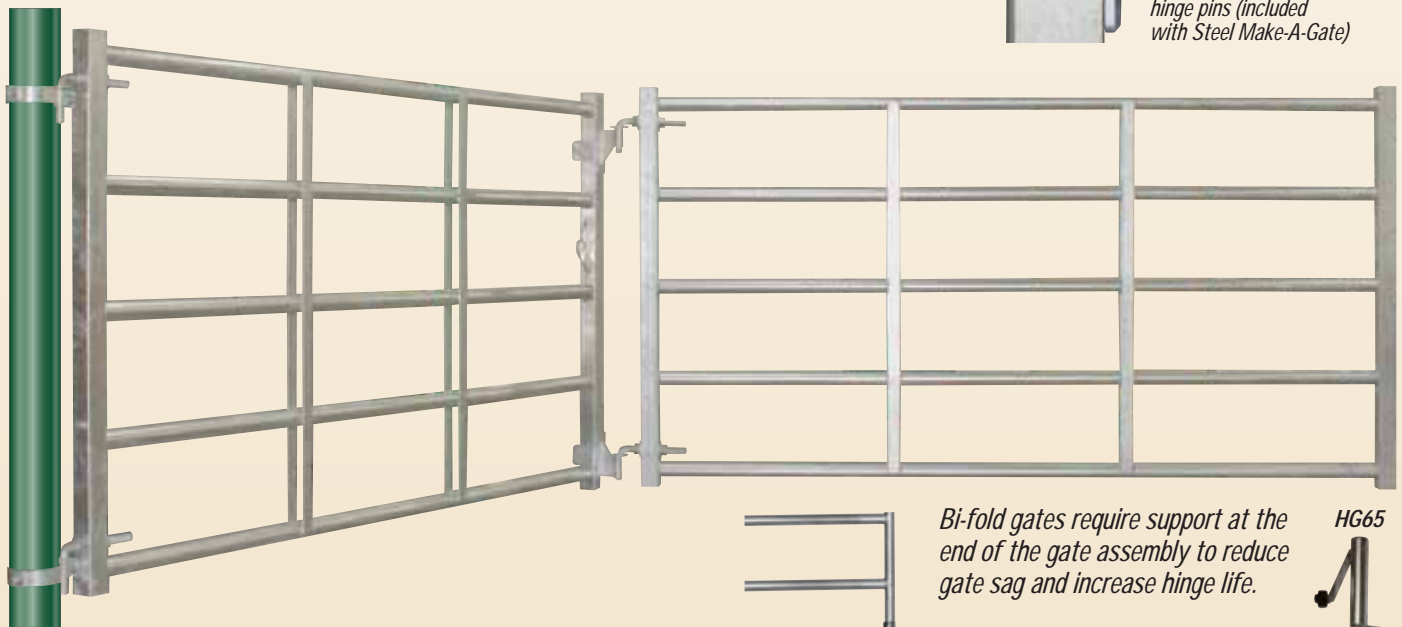

*Bi-fold gates require support at the end of the gate assembly to reduce gate sag and increase hinge life.*

*J&D highly recommends using our HG65 adjustable height gate wheel when creating a bi-fold gate. The 360° swivel will follow the swing of the gate when opening or closing.*



Part#	Description
HG48	(2) Bolt on Hinges for Steel Make-A-Gate, with Hardware
Accessories	
HG65	Gate Wheel, Adjustable Height